



Angular Contact Roller Bearings

High load carrying capacity with very small cross sections

Foreword

Axial ball bearings and axial cylindrical roller bearings are suitable for supporting high axial loads. However, these bearings should not be loaded in a radial direction and, on account of their cross section, require a relatively large radial installation space in the adjacent construction. Furthermore, single direction designs only support axial loads in one direction.

Yet applications frequently call for compact, load-bearing and rigid solutions, which can reliably support combined loads and moments with one bearing arrangement.

Very small cross section with maximum load carrying capacity

With angular contact roller bearings AXS, Schaeffler has developed a bearing series with a high load carrying capacity and a particularly small cross section. The design layout, cylindrical rollers (line contact at the contact surfaces) and nominal contact angle of $\alpha = 45^\circ$ or $\alpha = 60^\circ$ provide for high axial basic load ratings and very good rigidity.

Arranged in pairs, combined loads are also possible in addition to high axial loads in both directions.

High accuracy and rigidity

Angular contact roller bearings SGL are used in preference where not only high load carrying capacity but also high accuracy and rigidity is required.

The particularly high precision of angular contact roller bearings SGL is achieved by the use of machined, ground bearing rings with a triangular profile. The roller and cage assembly runs between these two hardened bearing rings. The cylindrical rollers are guided by a cage made from wear-resistant plastic. The nominal contact angle for SGL bearings is generally $\alpha = 45^\circ$.

Compact and economical

The bearing series stand for compact, light and economical bearing arrangements with high axial, radial and tilting moment loading.

For high tilting rigidity values, the bearings can be fitted in an O arrangement. Where necessary, the bearings can be preloaded to give freedom from axial clearance using an adjusting nut.

The series meet the demands for the minimum required installation space with a simultaneously high load carrying capacity and level of rigidity and therefore support the requirement for bearing arrangements with a reduced installation space and a high level of performance.

Other products Radial and axial needle roller and cage assemblies

The range of angular contact ball bearings is supplemented by radial and axial needle roller and cage assemblies produced by bending flat cages of series BF.

They are principally suitable for bearing arrangements with large shaft diameters. Due to their design, it is possible to produce cages of any diameter required.

The needle roller and cage assemblies and the associated axial bearing washers are described in TPI 203, Radial and axial needle roller and cage assemblies, axial bearing washers.

Contents

	Page
Angular contact roller bearings AXS.....	4
Angular contact roller bearings SGL.....	14
Applications	26
Other products	36



FAG



Angular contact roller bearings AXS

Angular contact roller bearings AXS

	Page
Product overview	Angular contact roller bearings AXS..... 6
Features	Load carrying capacity 7
	Operating temperature..... 7
	Applications 7
Design and safety guidelines	Dynamic load carrying capacity and life 8
	Basic rating life..... 8
	Static load safety factor 10
	Design of adjacent parts 11
	Preload..... 11
	Lubrication 11
Dimension tables	Angular contact roller bearings..... 12

Product overview Angular contact roller bearings AXS

Angular contact roller bearing

AXS



Angular contact roller bearings AXS

Features	<p>Angular contact roller bearings AXS comprise thin, formed bearing rings, between which injection-moulded plastic cages with cylindrical rollers are arranged. The dimensions and tolerances of the rolling elements conform to DIN ISO 5402-1. The modified line contact between the cylindrical rollers and raceways prevents damaging edge stresses.</p> <p>In contrast to comparable axial rolling bearings, series AXS has a particularly small cross section, whilst the load carrying capacity and tilting rigidity are very high in relation to the loaded installation space. Due to the small cross section of the bearing rings, radial section heights of just 7 mm to 10 mm can be achieved. This permits very compact bearing arrangements with a high load carrying capacity.</p> <p>Turned contact surfaces suffice for the bearing rings. As a result, the adjacent construction can be designed economically.</p> <p>The ready-to-fit machine elements are not self-retaining and are therefore very easy to assemble, as the individual parts can be fitted separately.</p>
Load carrying capacity	<p>The bearings can also support high tilting moments in addition to axial and radial loads. When fitted in pairs, even high loads are reliably supported.</p>
O or X arrangement	<p>Angular contact roller bearings are suitable for O and X arrangements. In the O arrangement, the cones and their apexes formed by the pressure lines point outwards; in the X arrangement, the cones point inwards.</p> <p>The support base, in other words the distance between the apexes of the contact cones, is wider in the O arrangement than in the X arrangement. Bearing arrangements with the bearings in the O arrangement are particularly resistant to tilting.</p>
Contact angle	<p>In order to cater particularly well to the specific requirements of the complex application areas, series AXS is available with contact angles of 45° and 60°. The greater the contact angle, the higher the axial load to which the bearing can be subjected.</p> <p>Designs with a contact angle of 45° are particularly suitable for axial, radial and tilting moment loads and those with a contact angle of 60° for predominantly axial loads and tilting moments.</p>
Operating temperature	<p>The bearings are suitable for operating temperatures of -20 °C to +120 °C.</p>
Applications	<p>The new series has a wide application field.</p> <p>It is particularly suitable for:</p> <ul style="list-style-type: none">■ combined loads (axial and radial) with simultaneously high exposure to tilting moments■ small axial and radial installation spaces■ swivelling operation■ low speeds

Angular contact roller bearings AXS

Design and safety guidelines

Dynamic load carrying capacity and life

The fatigue behaviour of the material determines the dynamic load carrying capacity of a rolling bearing.

The dynamic load carrying capacity is described in terms of the basic dynamic load rating and the basic rating life L_{10} or L_{10h} in accordance with DIN ISO 281.

The fatigue life is dependent on:

- load
- operating speed
- the statistical probability of the first appearance of failure

The dynamic load rating C (C_a , C_r) applies to rotating rolling bearings.

Basic rating life

The basic rating life L_{10} and L_{10h} is determined from:

$$L_{10} = \left(\frac{C}{P} \right)^p$$

$$L_{10h} = \frac{16\,666}{n} \cdot \left(\frac{C}{P} \right)^p$$

L_{10} 10^6 revolutions

The basic rating life in millions of revolutions is the life reached or exceeded by 90% of a sufficiently large group of apparently identical bearings before the first evidence of material fatigue develops

L_{10h} h

The basic rating life as defined for L_{10} but expressed in operating hours

C (C_a , C_r) N

Basic dynamic axial or radial load rating

P N

Equivalent dynamic bearing load for combined load

p -

Life exponent for roller bearings: $p = 10/3$

n min^{-1}

Operating speed

Equivalent dynamic bearing load

The equivalent dynamic bearing load P is a calculated value. This value is constant in size and direction; it is a radial load for radial bearings and an axial load for axial bearings.

P gives the same rating life as the combined load occurring in practice.

$$P = X \cdot F_r + Y \cdot F_a$$

P N
Equivalent dynamic bearing load for combined load

F_a, F_r N
Axial or radial dynamic bearing load

X –
Calculation factor (radial load factor)

Y –
Calculation factor (axial load factor)

Calculation factors

Angular contact roller bearing	Nominal contact angle α °	$F_r/F_a <^1)$	Calculation factors	
			X	Y
AXS0816	45	0,67	1	1
AXS1220	60	0,39	1,73	1
AXS2034	60	0,39	1,73	1
AXS3550	60	0,39	1,73	1
AXS4558	45	0,67	1	1
AXS6074	60	0,39	1,73	1
AXS8599	60	0,39	1,73	1
AXS100115	60	0,39	1,73	1
AXS115129	60	0,39	1,73	1
AXS120134	60	0,39	1,73	1
AXS140154	60	0,39	1,73	1
AXS145169	45	0,67	1	1
AXS150164	60	0,39	1,73	1
AXS160180	60	0,39	1,73	1
AXS175200	45	0,67	1	1

¹⁾ Where higher radial load is present, more detailed calculation is necessary.

Angular contact roller bearings AXS

Static load safety factor

In addition to dimensioning on the basis of the fatigue limit life, it is advisable to check the static load safety factor S_0 .

The static load safety factor indicates the security against impermissible permanent deformations in the bearing.

$$S_0 = \frac{C_0}{P_0}$$

S_0 – Static load safety factor
 C_0 (C_{0a} , C_{0r}) N Basic static axial or radial load rating
 P_0 N Equivalent static bearing load for axial bearings

Equivalent static load

The equivalent static load P_0 is a calculated value. It corresponds to a concentric axial load in axial bearings.

P_0 induces the same load at the centre point of the most heavily loaded contact point between the rolling element and raceway as the combined load occurring in practice.

$$P_0 = X_0 \cdot F_{0r} + Y_0 \cdot F_{0a}$$

P_0 N Equivalent static bearing load for combined load
 F_{0a} , F_{0r} N Axial or radial static bearing load
 X_0 – Calculation factor (radial load factor)
 Y_0 – Calculation factor (axial load factor)

Calculation factors

Angular contact roller bearing	Nominal contact angle α °	$F_r/F_a < 1$	Calculation factors	
			X_0	Y_0
AXS0816	45	0,67	2,3	1
AXS1220	60	0,39	3,98	1
AXS2034	60	0,39	3,98	1
AXS3550	60	0,39	3,98	1
AXS4558	45	0,67	2,3	1
AXS6074	60	0,39	3,98	1
AXS8599	60	0,39	3,98	1
AXS100115	60	0,39	3,98	1
AXS115129	60	0,39	3,98	1
AXS120134	60	0,39	3,98	1
AXS140154	60	0,39	3,98	1
AXS145169	45	0,67	2,3	1
AXS150164	60	0,39	3,98	1
AXS160180	60	0,39	3,98	1
AXS175200	45	0,67	2,3	1

¹⁾ Where higher radial load is present, more detailed calculation is necessary.

Design of adjacent parts

The bearing rings must be fully supported on their entire surface. They must be centred radially on the shaft or in the housing.

The transitions from the centring features to the supporting faces must be kept free. Corner radii should have a maximum radius of 0,2 mm.

Supporting faces for washers, threads and centring features are produced in a single clamping operation.

Do not centre adjacent parts using the thread; separate centring feature provided.

The angularity, roundness and surface quality of the shaft and housing are critical factors in the smooth running and load bearing capability of the bearings.

Angular deviations of the contact surfaces must not exceed $\pm 1,5'$.

The cage is to be guided on the shaft. The diameter for cage guidance must be selected on the same basis as diameter d_a for centring the bearing ring on the shaft. In exceptional cases (at low speeds), cage guidance in the housing is possible. The cage must then be relieved internally on the shaft.

Radial cage guidance surfaces should be precision machined.

Preload

Bearing clearance or preload should be adjusted using an adjusting nut with a fine-pitch thread. The nut must be secured against loosening.

Preload must be checked by means of a friction coefficient measurement.

During adjustment, the units should be rotated several times, loosened again and then finally tightened.

If the bearings cannot be rotated during tightening, the preload can also be applied in stages: tighten, loosen, turn the bearings into place. This process must be repeated several times in order to align the rolling elements correctly.

Lubrication

The bearing sets should be sufficiently greased prior to operation. Please contact Schaeffler for information on grease quantities.

A relubrication option should be provided for dynamic applications.

Angular contact roller bearings

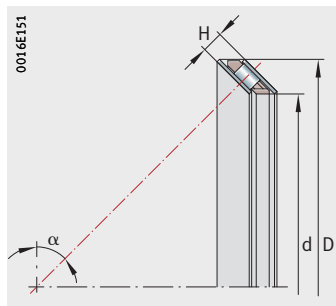

AXS

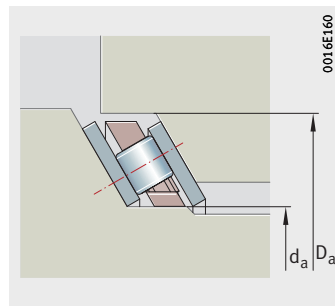

Centring of the bearing rings
(rapidly rotating application)

Dimension table · Dimensions in mm

Designation ¹⁾	Mass m ≈g	Dimensions			Contact angle ²⁾ α °
		d	D	H	
AXS0816	3	8	16	3 +0,26 / +0,06	45
AXS1220	3	12	20	3 -0,24 / -0,44	60
AXS2034	16	20	34	5 -0,1 / -0,2	60
AXS3550	27	35	50	6 -0,1 / -0,3	60
AXS4558	35	45	58	6 -0,1 / -0,3	45
AXS6074	36	60	74	5 0 / -0,6	60
AXS8599	60	85	99	6 0 / -0,5	60
AXS100115	70	101	115	6 0 / -0,5	60
AXS115129	65	115	129	5 0 / -0,5	60
AXS120134	80	120	134	6 0 / -0,5	60
AXS140154	90	140	154	6 0 / -0,3	60
AXS145169	267	145	169	7,4 +0,1 / -0,4	45
AXS150164	100	150	164	6 0 / -0,5	60
AXS160180	168	160	180	6 0 / -0,2	60
AXS175200	300	175	199	7,4 +0,1 / -0,4	45

Please request missing values.

- 1) Other dimensions by agreement.
- 2) 60° for predominantly axial loads and tilting moments.

Centring of the bearing rings		Basic load ratings			
on the shaft	in the housing	dyn.	stat.	dyn.	stat.
d_a	D_a	C_a	C_{0a}	C_r	C_{0r}
		N	N	N	N
8 -0,05 / -0,15	16,3 +0,15 / +0,05	3 600	6 300	1 510	1 270
12,2 -0,05 / -0,15	20,2 +0,15 / +0,05	3 400	7 800	–	–
20,2 -0,05 / -0,15	34,2 +0,15 / +0,05	9 800	25 000	–	–
35,2 -0,1 / -0,2	49,2 +0,2 / +0,1	18 200	52 000	–	–
45 -0,1 / -0,2	58 +0,2 / +0,1	18 200	56 000	7 600	11 200
60 -0,1 / -0,2	74 +0,2 / +0,1	15 600	62 000	–	–
85 -0,1 / -0,2	99 +0,2 / +0,1	26 500	109 000	–	–
101,2 -0,1 / -0,2	114,8 +0,2 / +0,1	30 500	139 000	–	–
115 -0,15 / -0,25	129 +0,25 / +0,15	21 600	115 000	–	–
120 -0,15 / -0,25	134 +0,25 / +0,15	31 500	152 000	–	–
140,2 -0,15 / -0,25	153,8 +0,25 / +0,15	36 000	190 000	–	–
145 -0,15 / -0,4	169 +0,25 / +0,15	76 000	400 000	31 500	80 000
150 -0,15 / -0,25	164 +0,25 / +0,15	35 500	190 000	–	–
160 -0,15 / -0,25	180 +0,25 / +0,15	68 000	405 000	–	–
175 -0,15 / -0,25	199 +0,25 / +0,15	84 000	480 000	34 500	96 000



FAG



Angular contact roller bearings SGL

Angular contact roller bearings SGL

	Page
Product overview	Angular contact roller bearing SGL..... 16
Features	Load carrying capacity 17
	Operating temperature..... 17
	Applications 17
Design and safety guidelines	Dynamic load carrying capacity and life 18
	Basic rating life..... 18
	Static load safety factor 20
	Design of adjacent parts 21
	Preload..... 21
	Lubrication 22
	Design of bearing arrangements..... 22
Dimension tables	Angular contact roller bearings..... 24

Product overview Angular contact roller bearings SGL

Angular contact roller bearing

SGL



Angular contact roller bearings SGL

Features

Bearings of the series SGL are preferably used if high accuracy and rigidity is required in addition to a high load carrying capacity.

The particularly high precision of angular contact roller bearings SGL is achieved by means of exact, machined, hardened and ground bearing rings with a triangular profile, *Figure 1*.

A roller and cage assembly from wear-resistant plastic is arranged between the bearing rings.

This results in very compact bearing arrangements with a high performance capacity.

The majority of angular contact roller bearings SGL correspond to dimension series 18 and are therefore interchangeable with angular contact ball bearings 718.

The use of quadratic rolling elements (diameter equals length) significantly improves the kinematic conditions in the bearing. The rolling behaviour of these rolling elements is practically ideal. The bearing gives particularly uniform and low-friction running and is suitable for high speeds.

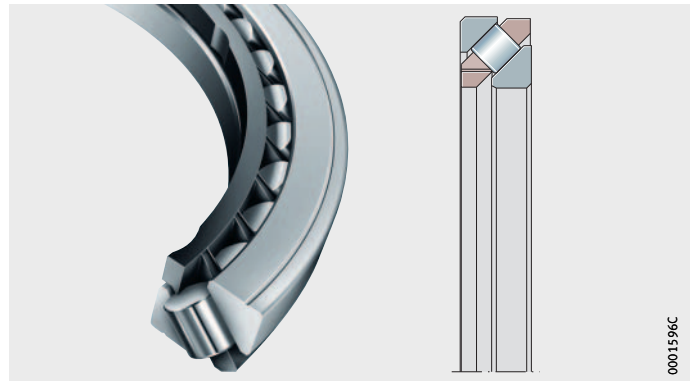

Figure 1
Angular contact roller bearing

Load carrying capacity

The bearings can also support high tilting moments in addition to axial and radial loads. When fitted in pairs, even high loads are reliably supported.

O or X arrangement

Angular contact roller bearings are suitable for O and X arrangements. The bearings are predominantly used in an O arrangement. The resulting large support distances increase the tilting rigidity of the bearing arrangement. Depending on the requirements, the bearing arrangement can be set to a condition ranging from bearing clearance to bearing preload.

Contact angle

The nominal contact angle is $\alpha = 45^\circ$. These designs are preferably suited to axial, radial and tilting moment loads.

Operating temperature

The bearings are suitable for operating temperatures of -20°C to $+120^\circ\text{C}$.

Applications

Angular contact roller bearings SGL have long proven successful in many high precision planetary gearboxes across a wide range of industrial areas, in machine tools and in the field of robots and handling.

Angular contact roller bearings SGL

Design and safety guidelines

Dynamic load carrying capacity and life

The fatigue behaviour of the material determines the dynamic load carrying capacity of a rolling bearing.

The dynamic load carrying capacity is described in terms of the basic dynamic load rating and the basic rating life L_{10} or L_{10h} in accordance with DIN ISO 281.

The fatigue life is dependent on:

- load
- operating speed
- the statistical probability of the first appearance of failure

The dynamic load rating C (C_a , C_r) applies to rotating rolling bearings.

Basic rating life

The basic rating life L_{10} and L_{10h} is determined from:

$$L_{10} = \left(\frac{C}{P} \right)^p$$

$$L_{10h} = \frac{16\,666}{n} \cdot \left(\frac{C}{P} \right)^p$$

L_{10} 10^6 revolutions

The basic rating life in millions of revolutions is the life reached or exceeded by 90% of a sufficiently large group of apparently identical bearings before the first evidence of material fatigue develops

L_{10h} h

The basic rating life as defined for L_{10} but expressed in operating hours

C (C_a , C_r) N

Basic dynamic axial or radial load rating

P N

Equivalent dynamic bearing load for combined load

p -

Life exponent for roller bearings: $p = 10/3$

n min^{-1}

Operating speed

Equivalent dynamic bearing load

The equivalent dynamic bearing load P is a calculated value. This value is constant in size and direction; it is a radial load for radial bearings and an axial load for axial bearings.

P gives the same rating life as the combined load occurring in practice.

$$P = X \cdot F_r + Y \cdot F_a$$

P N
Equivalent dynamic bearing load for combined load

F_a, F_r N
Axial or radial dynamic bearing load

X –
Calculation factor (radial load factor)

Y –
Calculation factor (axial load factor)

Calculation factors

Angular contact roller bearing	Nominal contact angle α °	$F_r/F_a <^1)$	Calculation factors	
			X	Y
SGL1730	45	0,67	0	1
SGL3042	45	0,67	0	1
SGL3547	45	0,67	0	1
SGL4052	45	0,67	0	1
SGL4558	45	0,67	0	1
SGL5065	45	0,67	0	1
SGL6078	45	0,67	0	1
SGL6585	45	0,67	0	1
SGL80100	45	0,67	0	1
SGL85110	45	0,67	0	1
SGL98130	45	0,67	0	1
SGL105130	45	0,67	0	1
SGL130165	45	0,67	0	1
SGL140175	45	0,67	0	1
SGL180225	45	0,67	0	1
SGL200250	45	0,67	0	1
SGL240310	45	0,67	0	1
SGL260320	45	0,67	0	1
SGL290330	45	0,67	0	1
SGL340400	45	0,67	0	1

¹⁾ Where higher radial load is present, more detailed calculation is necessary.

Angular contact roller bearings SGL

Static load safety factor

In addition to dimensioning on the basis of the fatigue limit life, it is advisable to check the static load safety factor S_0 .

The static load safety factor indicates the security against impermissible permanent deformations in the bearing.

$$S_0 = \frac{C_0}{P_0}$$

S_0	–
Static load safety factor	
C_0 (C_{0a} , C_{0r})	N
Basic static axial or radial load rating	
P_0	N
Equivalent static bearing load for axial bearings	

Equivalent static load

The equivalent static load P_0 is a calculated value. It corresponds to a concentric axial load in axial bearings.

P_0 induces the same load at the centre point of the most heavily loaded contact point between the rolling element and raceway as the combined load occurring in practice.

$$P_0 = X_0 \cdot F_{0r} + Y_0 \cdot F_{0a}$$

P_0	N
Equivalent static bearing load for combined load	
F_{0a} , F_{0r}	N
Axial or radial static bearing load	
X_0	–
Calculation factor (radial load factor)	
Y_0	–
Calculation factor (axial load factor)	

Calculation factors

Angular contact roller bearing	Nominal contact angle α °	$F_r/F_a <^{1)}$	Calculation factors	
			X_0	Y_0
SGL1730	45	0,67	2,3	1
SGL3042	45	0,67	2,3	1
SGL3547	45	0,67	2,3	1
SGL4052	45	0,67	2,3	1
SGL4558	45	0,67	2,3	1
SGL5065	45	0,67	2,3	1
SGL6078	45	0,67	2,3	1
SGL6585	45	0,67	2,3	1
SGL80100	45	0,67	2,3	1
SGL85110	45	0,67	2,3	1
SGL98130	45	0,67	2,3	1
SGL105130	45	0,67	2,3	1
SGL130165	45	0,67	2,3	1
SGL140175	45	0,67	2,3	1
SGL180225	45	0,67	2,3	1
SGL200250	45	0,67	2,3	1
SGL240310	45	0,67	2,3	1
SGL260320	45	0,67	2,3	1
SGL290330	45	0,67	2,3	1
SGL340400	45	0,67	2,3	1

¹⁾ Where higher radial load is present, more detailed calculation is necessary.

Design of adjacent parts

The perpendicularity, roundness and surface quality of the shaft and housing are critical factors in the smooth running and load bearing capacity of the bearings.

Preload

Bearing clearance or preload should be adjusted using an adjusting nut with a fine-pitch thread. The nut must be secured against loosening.

Preload must be checked by means of a friction coefficient measurement.

During adjustment, the units should be rotated several times, loosened again and then finally tightened.

If the bearings cannot be rotated during tightening, the preload can also be applied in stages: tighten, loosen, turn the bearings into place. This process must be repeated several times in order to align the rolling elements correctly.

Angular contact roller bearings SGL

Lubrication It should be determined as early as possible in the design process whether bearings are to be lubricated using grease or oil.

The following factors are decisive in determining the type of lubrication and quantity of lubricant:

- the operating conditions
- the type and size of the bearing
- the adjacent construction
- the lubricant feed

Criteria for grease lubrication In the case of grease lubrication, the following criteria must be considered:

- very little design work required
- the sealing action
- the reservoir effect
- long operating life with little maintenance work (lifetime lubrication possible in certain circumstances)
- if relubrication is required, it may be necessary to provide collection areas for old grease and feed ducts
- no heat dissipation by the lubricant
- no rinsing out of wear debris and other particles

Criteria for oil lubrication In the case of oil lubrication, the following criteria must be considered:

- good lubricant distribution and supply to contact areas
- dissipation of heat possible from the bearing (significant principally at high speeds and loads)
- rinsing out of wear particles
- very low friction losses with minimal quantity lubrication
- more work required on feed and sealing

Design of the bearing arrangement

Radial location

In addition to supporting the rings adequately, the bearings must be securely located in a radial direction, to prevent creep of the bearing rings on the mating parts under load. This is generally achieved by means of tight fits between the bearing rings and the adjacent seating surfaces.

For angular contact roller bearings in high precision applications, we recommend the following fits:

- k6 for the shaft
- N6 for the housing bore

Axial location

As a tight fit alone is not normally sufficient to locate the bearing rings securely on the shaft and in the housing bore in an axial direction, this should be supported by means of an additional axial location or retention method.

The axial location of the bearing rings must be matched to the selected type of bearing arrangement. Shaft and housing shoulders, housing covers, nuts, spacer rings and retaining rings are fundamentally suitable.

Dimensional, geometrical and running accuracy of the bearing seats

The accuracy of the cylindrical bearing seat on the shaft and in the housing should correspond to the accuracy of the bearing used. The tolerances of the bearing seating surfaces that must be observed for angular contact roller bearings SGL are given in the table.

Guide values for the geometrical and positional tolerances of bearing seating surfaces

Nominal dimension d		Roundness tolerance Shaft, housing μm	Total axial run-out tolerance	Flatness	Corner radius r_a mm max.	Coaxiality μm
			Abutment shoulders			
mm over	incl.		μm	μm		
-	30	3	4	8	0,3	3
30	50	4	4	8	0,3	4
50	80	4	5	10	0,3	4
80	120	5	6	10	0,6	5
120	180	6	8	15	0,8	6
180	250	7	10	20	1	7
250	315	8	12	24	1	8
315	400	9	13	26	1,2	9

Roughness of cylindrical bearing seats

The roughness of the bearing seats must be matched to the tolerance class of the bearings. The surface quality of the bearing seating surfaces must not fall below Ra 1,2.

Mounting dimensions for the contact surfaces of bearing rings

The mounting dimensions for the contact surfaces of the bearing rings such as shaft and housing shoulders or to the spacer rings must be of sufficient height. However, they must also reliably prevent rotating parts of the bearing from grazing stationary parts. Proven mounting dimensions for the diameters of the abutment shoulders are limiting dimensions (maximum or minimum dimensions) and should not be higher or lower than the specified values, see dimension table.

Cage projection

In the open bearings, the cages project laterally to a certain extent. In order to prevent the cages from grazing the adjacent construction, the lateral minimum distances s must be taken into consideration in the design of the adjacent construction.

s = minimum distance, see dimension table

Figure 2
Minimum distance to the adjacent construction

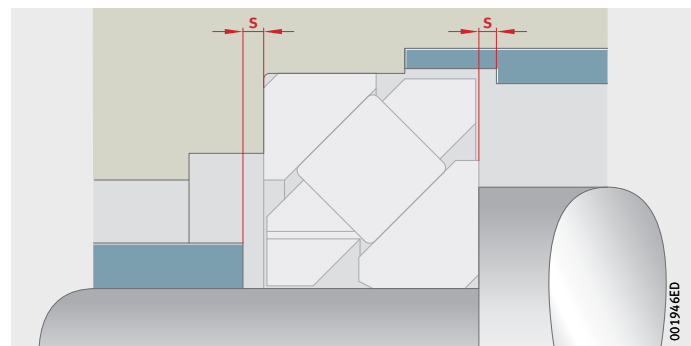

Angular contact roller bearings

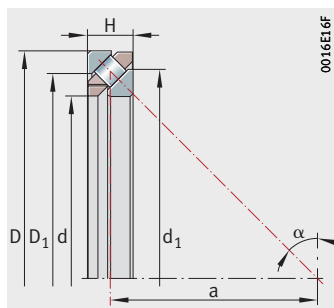

SGL

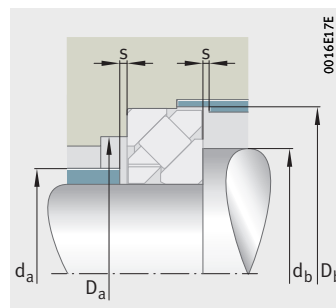

Centring of the bearing rings

Dimension table · Dimensions in mm

Designation ¹⁾	Ordering designation	Mass m ≈ kg	Dimensions						Dimension series to DIN 623-1
			d	D	H	D ₁	d ₁	a	
SGL1730	F-587391.SGL	0,015	17	30	7	22,5	24,5	11,75	–
SGL3042	F-587397.SGL	0,022	30	42	7	34,5	37,5	18	–
SGL3547	F-618875.SGL	0,024	35	47	7	40	42	20,5	–
SGL4052	F-557493.SGL	0,026	40	52	7	45,5	46,5	23	1808
SGL4558	F-238341.SGL	0,033	45	58	7	51	52,2	25,75	1809
SGL5065	F-557494.SGL	0,042	50	65	7	57,3	57,7	28,75	1810
SGL6078	F-238166.SGL	0,085	60	78	10	68	70	34,5	1812
SGL6585	F-557495.SGL	0,106	65	85	10	75	77	37,5	1813
SGL80100	F-238167.SGL	0,12	80	100	10	90	92	45	1816
SGL85110	F-587396.SGL	0,228	85	110	13	96	99	48,75	1817
SGL98130	F-238584.SGL	0,42	98	130	16	113	115	57	–
SGL105130	F-240120.SGL	0,269	105	130	13	116,5	118,5	58,75	1821
SGL130165	F-631562.SGL	0,64	130	165	17,5	146	149	73,75	–
SGL140175	F-550953.SGL	0,69	140	175	18	156	159	78,75	1828
SGL180225	F-550954.SGL	1,44	180	225	22	200	205	101,25	1836
SGL200250	F-565516.SGL	1,93	200	250	24	222,5	227,5	112,5	1840
SGL240310	F-571366.SGL	4,55	240	310	33	272	278	137,5	–
SGL260320	F-555613.SGL	3	260	320	30	287	293	145	–
SGL290330	F-614821.SGL	1,78	290	330	20	307,4	312,6	155	–
SGL340400	F-565223.SGL	4,85	340	400	30	367	373	185	–

Nominal contact angle $\alpha = 45^\circ$.

¹⁾ Other dimensions by agreement.

Mounting dimensions				Basic load ratings				Fatigue limit loads		Reference speed	Limiting speed
D _a	d _b	D _{b min}	s	dyn. C _r N	stat. C _{0r} N	dyn. C _a N	stat. C _{0a} N	C _{ur} N	C _{ua} N	n _{gr} min ⁻¹	n _G min ⁻¹
22,5	24,5	31	1	3 500	3 550	8 400	17 700	610	2 480	7 000	3 200
34,5	37,5	43	1	4 400	5 500	10 600	27 500	940	3 850	5 100	2 100
40	42	48	1	4 800	6 400	11 500	32 000	1 110	4 500	4 600	1 800
45,5	46,5	53	1	6 900	9 600	16 600	48 000	1 650	6 700	4 300	1 600
51	52,2	59	1	7 600	11 200	18 200	56 000	1 950	7 900	3 900	1 400
57,3	57,7	66	1	9 900	14 900	23 700	75 000	1 730	7 000	3 600	1 300
68	70	79	1	14 300	21 700	34 500	109 000	2 500	10 200	3 200	1 100
75	77	86	1	15 000	23 900	36 000	119 000	2 750	11 200	3 000	1 000
90	92	101	1,5	16 600	29 000	40 000	144 000	3 350	13 600	2 500	850
96	99	111	1,5	21 400	36 000	51 000	180 000	4 350	17 700	2 400	750
113	115	131	1,5	37 000	63 000	89 000	315 000	7 700	31 000	2 200	650
116,5	118,5	131	1,5	28 500	52 000	68 000	260 000	6 000	24 400	2 000	600
146	149	166	1,5	49 000	90 000	118 000	450 000	8 600	35 000	1 800	500
156	159	176	1,5	50 000	95 000	121 000	475 000	9 000	36 500	1 700	450
200	205	226	2	75 000	151 000	181 000	750 000	14 400	58 000	1 500	350
222,5	227,5	251	2	100 000	199 000	240 000	990 000	19 000	77 000	1 300	300
272	278	311	2,5	153 000	320 000	370 000	1 600 000	31 000	125 000	1 200	250
287	293	321	2,5	126 000	280 000	305 000	1 390 000	25 500	103 000	1 100	250
307,4	312,6	331	2,5	84 000	217 000	203 000	1 090 000	17 600	72 000	1 000	200
367	373	401	3	181 000	440 000	435 000	2 200 000	39 000	158 000	900	200



FAG



Applications

Applications

		Page
Ceiling mount	Requirements	28
	Design solution.....	28
Painting robots	Requirements	29
	Design solution.....	29
Bicycle arm	Requirements	30
	Design solution.....	30
Computer tomograph	Requirements	31
	Design solution.....	31
Tracking systems for solar plants	Requirements	32
	Design solution.....	33
High precision planetary gearboxes	Requirements	34
	Design solution.....	35

Ceiling mount

Ceiling mounts in operating theatres must reliably support an ever increasing number of heavier devices, whilst allowing the movable parts to swivel free from vibration and with low noise, even in strong magnetic fields, *Figure 1*. It is here that the classic mechanical components play a “supporting” role.

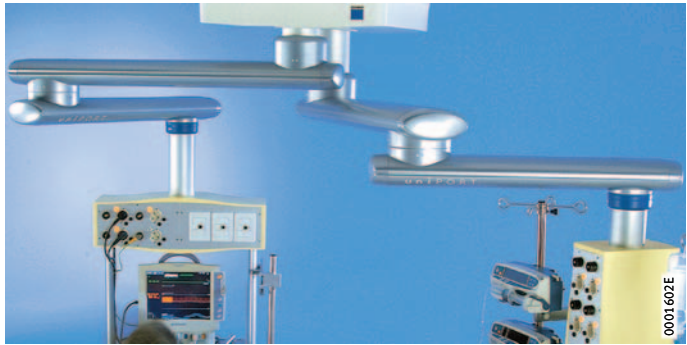

Figure 1
Ceiling mount

Requirements

The bearings must exhibit a high static load safety factor and tilting rigidity in the smallest possible installation space. The inside diameter should be relatively large, to allow the supply lines and cables to pass through easily.

Design solution

The bearing arrangement comprises a complete unit with double direction angular contact roller bearings AXS, *Figure 2*. As a result of the O arrangement, cylindrical rollers and contact angle of 60°, the units have a high axial load carrying capacity and exhibit significant radial stiffness. The bearings are preloaded to give freedom from axial clearance using an adjusting nut. As a result, no extensive adjustment work is required during fitting.

The outer ring of the unit is screwed directly on to the end face of the adjacent construction by means of a fixing thread. The large inside diameter provides sufficient space for the supply lines and cables.

The bearings have an initial greasing using a special grease and can be relubricated if required.

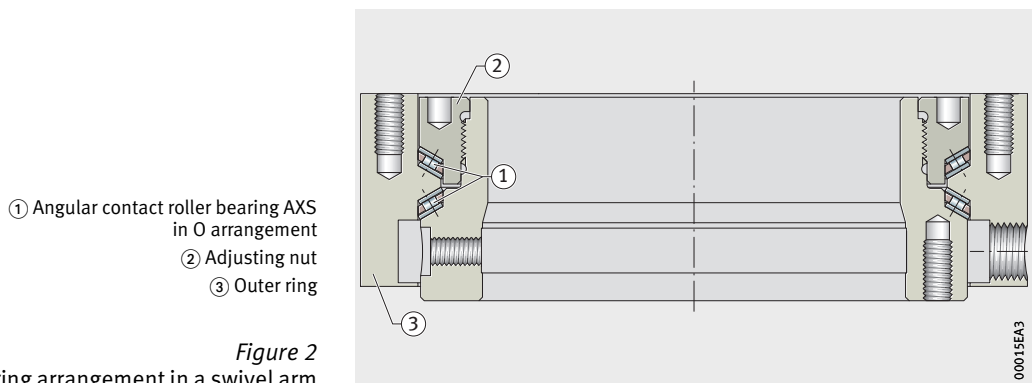

Figure 2
Bearing arrangement in a swivel arm

Products used

■ Angular contact roller bearing AXS

Painting robots

Painting robots are used in the automatic surface coating of bodywork and the parts attached to it, *Figure 1*. High-performance robots are available for coating components evenly and quickly.



Figure 1
Painting robots

Requirements

The most important part of the painting robot is the hand axis complete with paint sprayer. This hand axis should be light, compact, maintenance-free and easy to fit. It should also have sufficient space inside to accommodate the cable and hoses.

Design solution

The very small cross section of series AXS permits a compact design, *Figure 2*. The low weight of the bearings combined with a large diameter permits a light design with a high load carrying capacity and sufficient free space for the colour hoses.

The bearing clearance of the bearings used in an O arrangement is adjusted to a defined value with an adjusting nut.

These bearings are greased for life with special grease. The bearing position is sealed by a rotary shaft seal.

- ① Angular contact roller bearing AXS in O arrangement
- ② Grease chamber
- ③ Shaft
- ④ Adjusting nut
- ⑤ Housing
- ⑥ Rotary shaft seal

Figure 2
Bearing arrangement in hand axis

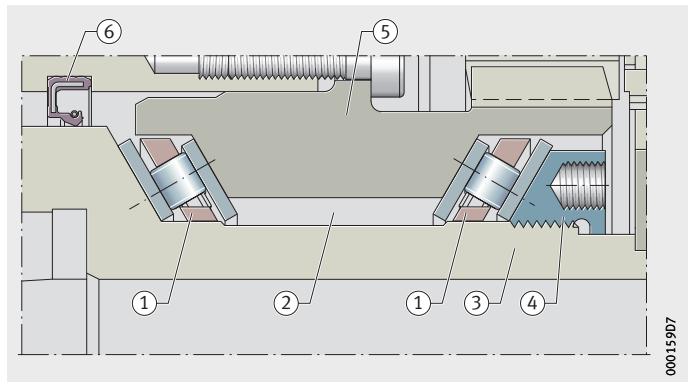

Products used

- Angular contact roller bearing AXS

Bicycle arm

For mountain bikes, an inconsistent requirement applies at first glance: Significant damping comfort and lightweight design combined with high rigidity and freedom from clearance, *Figure 1*.



Figure 1
Mountain bike

Requirements

Plain bearings and ball bearings in the rear construction cannot be adjusted to provide freedom from clearance. This, however, is at the expense of riding comfort. The bearing arrangement must therefore be adjustable to a defined value and reliably support the forces that occur as a result of exposure to the road surface and riding out of the saddle.

Design solution

The bearing units comprise double direction angular contact roller bearings AXS. As a result of the cylindrical rollers and the contact angle of 45°, the units have a high axial and radial load carrying capacity and exhibit significant radial stiffness, *Figure 2*.

Using an adjusting nut, the bearing units can be preloaded to give freedom from clearance and readjusted if required.

The bearing arrangement has a relubrication facility and is protected against contamination by toroidal rings.

- ① Angular contact roller bearing AXS
- ② Adjusting nut
- ③ Toroidal ring

Figure 2
Bearing arrangement
in a bicycle arm

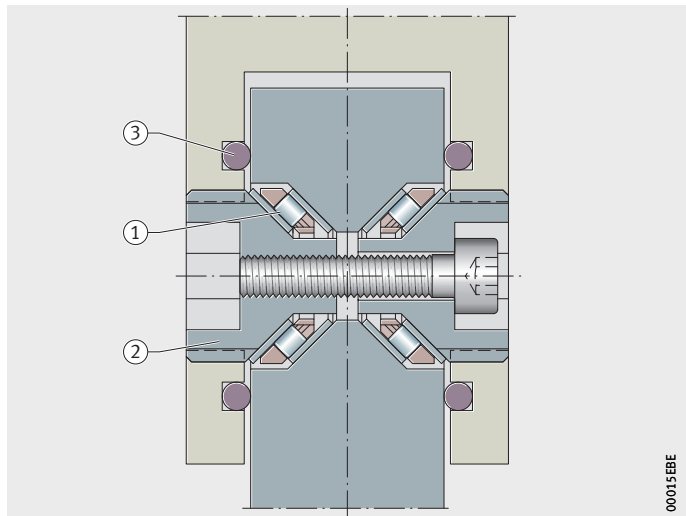

Products used

- Angular contact roller bearing AXS

Computer tomograph

In computer tomography, X-ray images are used to generate a three-dimensional image. A table, complete with the object to be x-rayed, is moved through the device within seconds. The table drive is controlled by an electromechanical ball screw drive.



Figure 1
Computer tomograph

Requirements

The locating bearing in the roller-burnished screw drive is intended to permit a simple adjacent geometry and short assembly times. Reduced weight and installation space, as well as design improvements, are also desired.

Design solution

Angular contact roller bearings ZAXFM are greased and preloaded ex-works. The adjusting nut is already incorporated in the bearing unit, *Figure 2*.

Bearing rings and adjusting nuts are machined from high-strength aluminium, whilst axial roller and cage assemblies and bearing washers are produced using non-machining methods.

The shorter rolling bearing design offers a greater spindle stroke and just one machined contact surface. Compared with an isometric version from rolling bearing steel, the bearing weight is reduced by 60% due to the aluminium rings.

The unit, which is only screw-mounted at the end face, improves the design of the linear actuator with its blue anodised outer ring.

① Angular contact roller bearing ZAXFM in O arrangement

Figure 2
Bearing arrangement in the ball screw drive

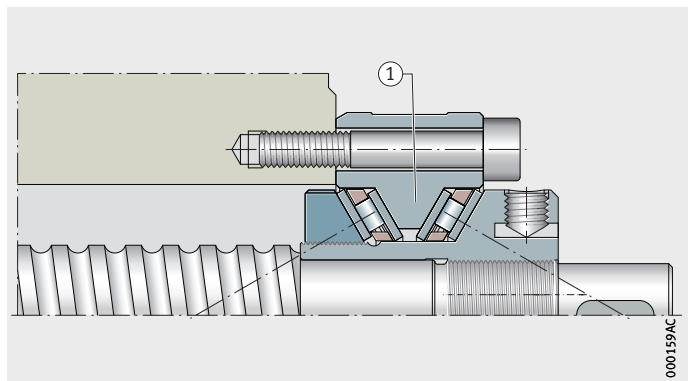

Products used

■ Angular contact roller bearing ZAXFM

Tracking systems for solar plants

As the largest energy source, the sun supplies an amount of energy which is approximately equivalent to 10 000 times the Earth's primary energy requirement each year.

One way of using the sun's energy is, for example, demonstrated by the so-called solar tower power plants, where hundreds of computer-controlled heliostats focus their light on one of the absorbers housed in a spire, *Figure 1*.

The concentration factor of the radiation reaches values of 1000 and above. With its support, the radiation is converted into heat, which is drawn off in order to drive a generator via a conventional turbine by means of steam generation.



Figure 1
Solar plants

Requirements

Various tracking systems have been developed so that the mirrors of a heliostat can be tracked as accurately as possible.

The bearing arrangement in the azimuth and elevation axis is particularly important where the tracking systems are concerned.

Design solution

The solution is a twin-axis tracking system, which follows the sun at various angles, *Figure 2*. This guarantees that the radiation angle of the sun hits the collector in its entirety. Orientation towards the sun can increase the efficiency of the sun collectors by 30% to 40%.

The twin-axis tracking system is also used to increase the potential of a solar reflector as a converter in the heliostat system.

With their features, angular contact roller bearings AXS permit compact, technically progressive and economical bearing arrangements for the azimuth and elevation axes.

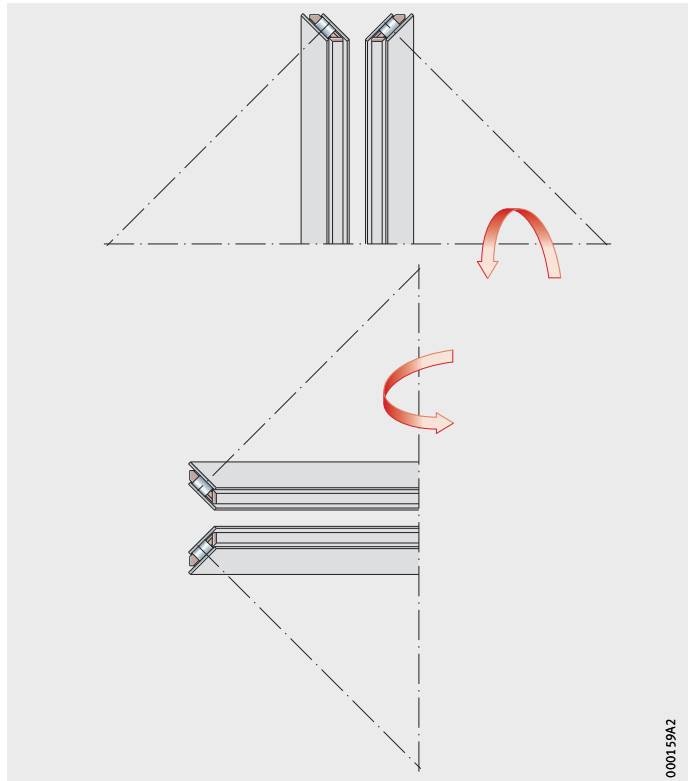

Figure 2
Installation position
and function lines

Products used

- Angular contact roller bearing AXS

High precision planetary gearboxes

High precision planetary gearboxes are used in handling systems such as delta robots as well as in workpiece and tool management systems.

Other areas of application include:

- automation
- robots
- DTS (driverless transport systems)



Source: Neugart GmbH

Figure 1
High precision planetary gearboxes

Requirement

High precision planetary gearboxes with drive flange have the highest requirements for tilting and torsional rigidity, in order to enable high positional accuracy.

The bearing arrangement of the drive flange has a decisive influence on gearbox precision. Any deflection or distortion of the bearing arrangement, and hence of the planetary carrier, results in hysteresis and backlash of the gearbox.

The bearing position on the outside of the planetary carrier and drive flange determines the external dimension and section height of the gearbox. A compact bearing solution offers considerable advantages here.

High precision planetary gearboxes are configured as single-stage or double-stage modular gearbox designs.

Design solution

To support the drive, angular contact roller bearings SGL are fitted in an O arrangement. With a nominal contact angle of $\alpha = 45^\circ$ in each case, a maximum support width can be achieved.

In combination with the preload and the line contact of the cylindrical rollers, a higher rigidity is achieved than would be possible with, for example, angular contact ball bearings or tapered roller bearings.

As a result of the modular design concept, angular contact roller bearings SGL are also interchangeable with bearings of dimension series 18. In fast running planetary stages with low torque, a bearing arrangement composed of angular contact ball bearing 718 is beneficial and can be replaced without changing the adjacent parts.

The bearings are mounted and preloaded with the aid of a precision adjusting nut. The bearing position is sealed by a rotary shaft seal.

- ① Angular contact roller bearing SGL
- ② Planetary carrier
- ③ Adjusting nut
- ④ Rotary shaft seal
- ⑤ Housing
- ⑥ Thrust washer
- ⑦ Planetary gear
- ⑧ Planetary bearing arrangement
- ⑨ Planetary stud

Figure 2
Angular contact roller bearing SGL
in O arrangement

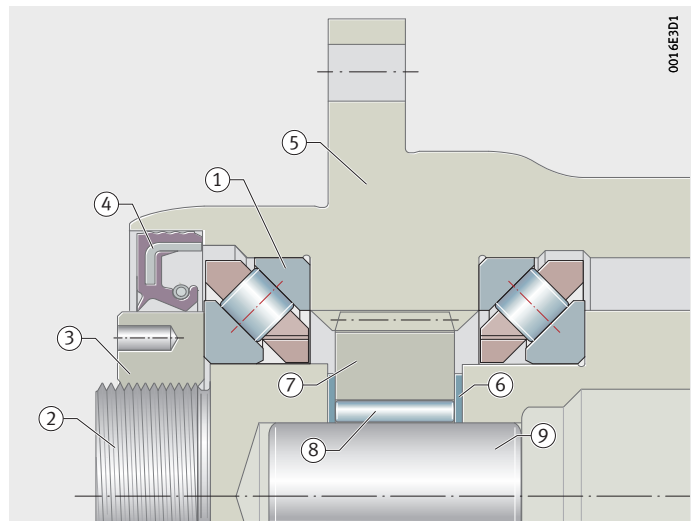

Products used

- Angular contact roller bearing SGL



FAG

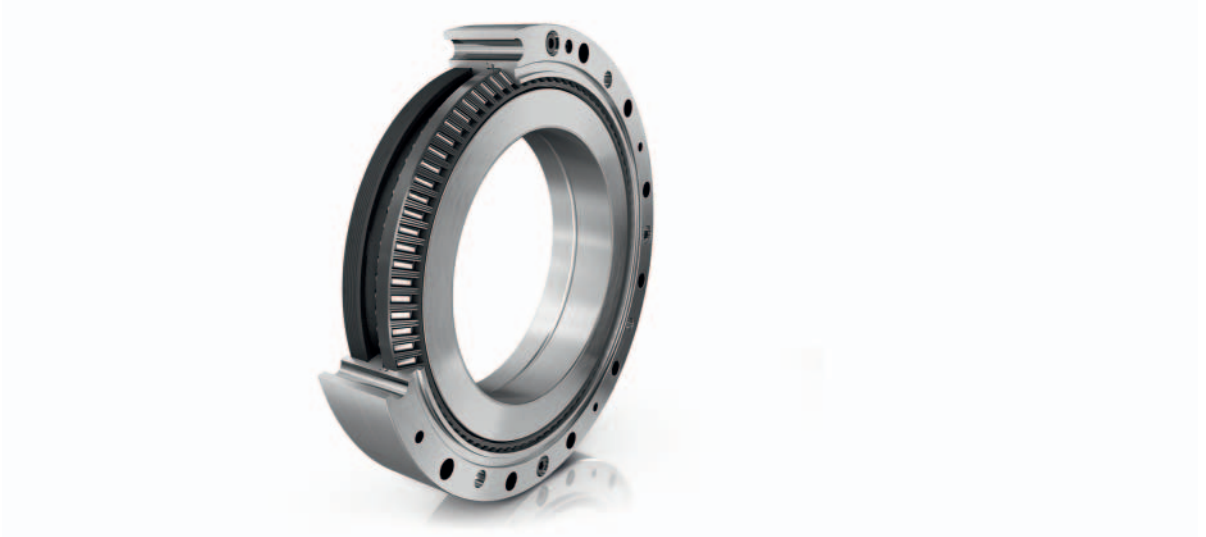

Other products

Other products

	Page
Angular contact roller bearings as ready-to-fit unit	
Features	38
Applications	38
Angular contact roller bearings with electromagnetic brake	
Features	39
Brake function	39
Applications	39
Axial angular contact needle roller bearings for robotics	
Features	40
Available sizes.....	41
Applications	41

Angular contact roller bearings as ready-to-fit unit

Features This design corresponds to a complete assembly comprising angular contact roller bearing AXS, which is individually tailored to the customer's requirements.

These units comprise:

- outer and inner ring with fixing thread
- adjusting nut
- double direction angular contact roller bearing in an O arrangement

As a result of the O arrangement and the contact angle of 60°, the bearing units have a high load carrying capacity and exhibit significant radial stiffness.

Bearing rings and adjusting nuts are precision-turned parts from high-strength steel, whilst axial roller and cage assemblies and axial bearing washers are produced using non-machining methods.

On request, units are available with:

- friction linings (strips, pads) for setting a minimum frictional resistance
- stop systems (smaller and larger than 360°) to restrict travel
- coatings (Corrotect, powder coating)

ZAXFM

Figure 1
Angular contact roller bearing
as ready-to-fit unit



Applications Preferred areas of application for angular contact roller bearings ZAXFM:

- handling and automation sector
- hoisting and conveying equipment
- packaging technology
- medical engineering
- general machine construction
- theatre and stage technology

Angular contact roller bearings with electromagnetic brake

Features

This design corresponds to a complete assembly comprising angular contact roller bearing AXS with electromagnetic brake. The brake prevents the bearing unit from rotating in a currentless state.

These units comprise:

- outer ring with fixing thread
- inner ring with coil and pressure springs
- adjusting nut with fixing thread
- anchor plate with an axial movement facility
- a lining plate connected to the outer ring
- double direction angular contact roller bearing in an O arrangement

As a result of the O arrangement and the contact angle of 60°, the bearing units have a high load carrying capacity and exhibit significant radial stiffness.

Bearing rings and adjusting nuts are precision-turned parts from high-strength steel, whilst axial roller and cage assemblies and axial bearing washers are produced using non-machining methods.

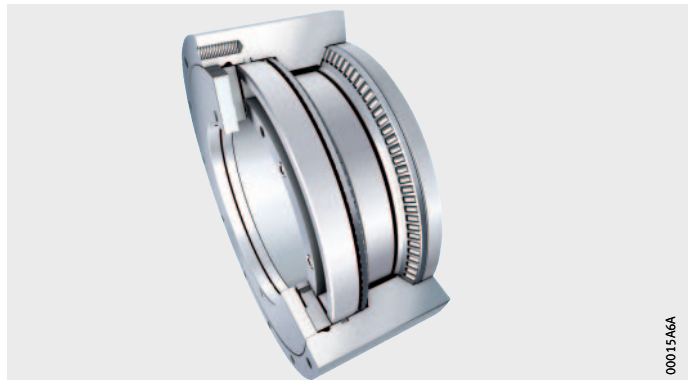

ZAXB

Figure 1
Angular contact roller bearings
with electromagnetic brake

Brake function

In a currentless state, the springs press the anchor plate against the brake lining, the unit decelerates.

When current is supplied, the electromagnet pulls the anchor plate against the springs and releases the brake lining so that the unit can rotate.

Applications

Preferred areas of application for angular contact roller bearings ZAXB:

- handling and automation sector
- hoisting and conveying equipment
- packaging technology
- medical engineering
- general machine construction
- theatre and stage technology

Axial angular contact needle roller bearings for robotics

Features

The axial angular contact needle roller bearing XZU, which is tailored to the requirements of robotics, can be used as the articulated arm bearing for lightweight and collaborative robots and as the main bearing for the reduction gear unit in robot joints (cobots).

The needle rollers are configured in an X arrangement in two raceways, each with a nominal contact angle $\alpha = 45^\circ$.

In comparison with crossed roller bearings, the axial angular contact needle roller bearing XZU has a larger number of load-bearing rolling elements and larger support spacings. Depending on the size, rigidity is increased by at least 30%.

The rolling elements are guided in two rows in cages. As a result, friction in the bearing is reduced by 20% and, most notably, occurs in a more uniform manner.

The ready-to-fit bearing is preloaded, sealed on one side and greased.

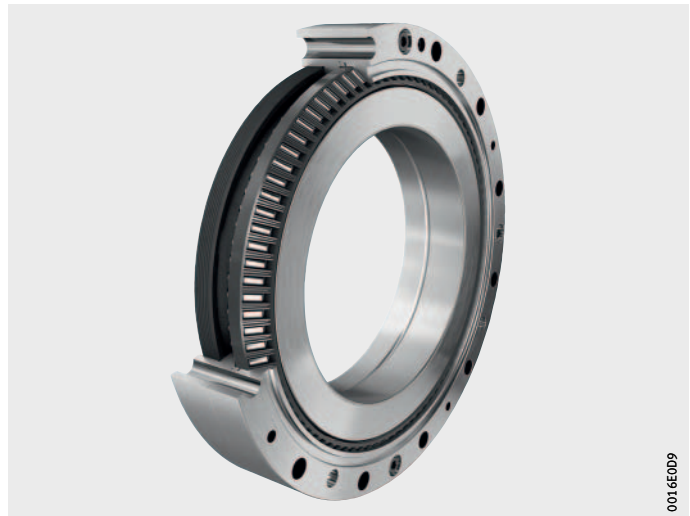

XZU

Figure 1
Axial angular contact needle
roller bearings for robotics

Available sizes Axial angular contact needle roller bearing XZU is available in the following dimensions for strain wave gearing sizes.

Sizes

Series	Dimensions		
	d _i mm	D _a mm	H mm
XZU-RTWH11	30	62	13
XZU-RTWH14	36	70	13,7
XZU-RTWH17	46	80	17
XZU-RTWH20	52	90	18,5
XZU-RTWH25	65	110	20,7
XZU-RTWH32	84,3	142	24,4
XZU-RTWH40	106	170	30

Applications

Areas of application for axial angular contact needle roller bearings XZU:

- articulated arm bearing for lightweight and collaborative robots (cobots)
- main bearing arrangement for reduction gear unit in robots
- medical engineering
- handling and automation
- general machine construction

**Schaeffler Technologies
AG & Co. KG**

Georg-Schäfer-Straße 30
97421 Schweinfurt
Germany
www.schaeffler.de/en
info.de@schaeffler.com

In Germany:

Phone 0180 5003872

From other countries:

Phone +49 9721 91-0

All information has been carefully compiled and checked by us, but we cannot guarantee complete accuracy. We reserve the right to make corrections. Therefore, please always check whether more up-to-date or amended information is available. This publication supersedes all deviating information from older publications. Printing, including excerpts, is only permitted with our approval.
© Schaeffler Technologies AG & Co. KG
TPI 185 / 01 / en-GB / DE / 2021-09